

Ventilation Fan Speed Controller

2 & 4 amp (for single phase motors)

Installation & operating instructions

Surface mount steps 1 2 3 4 5
 Recessed mount steps 3 4 5 6

In the box

	SURFACE	RECESSED
• Fascia & capsule assembly	✓	✓
• Surface enclosure	✓	X
• M3.5 fascia screws x2	✓	✓
• No.6 wall screws & rawl plugs x4	✓	X

1

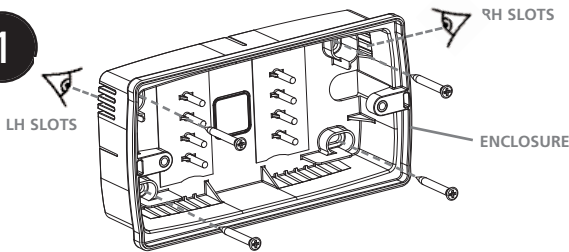

A Secure surface enclosure to the wall using the No.6 wall screws (supplied).

Note: Position the surface enclosure with the slots in the side walls (LH/RH) in the upper position (see diagram).

2

B Choose position for the conduit (circular or rectangular can be used) in either the 12, 3, 6 or 9 o'clock position.

C Use end of the guide slot (see arrow) in chosen position to locate centre of 20mm circular cutter, for circular conduit (see diagram).

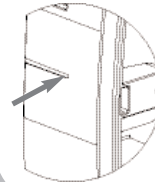

20mm CORING POINT AT END OF GUIDE SLOT (4 PLACES)

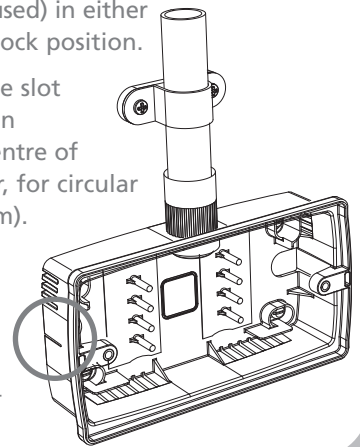

3

D Connect mains and control cables exiting from conduit to the terminal block.

Note: If no conduit is needed; mains cables can enter the surface enclosure through the 'knock-out' panel.

Note: When power is first switched on 2 LED's on the front panel will alternate for 3 seconds to show unit is operating.

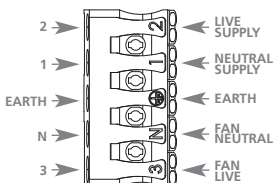
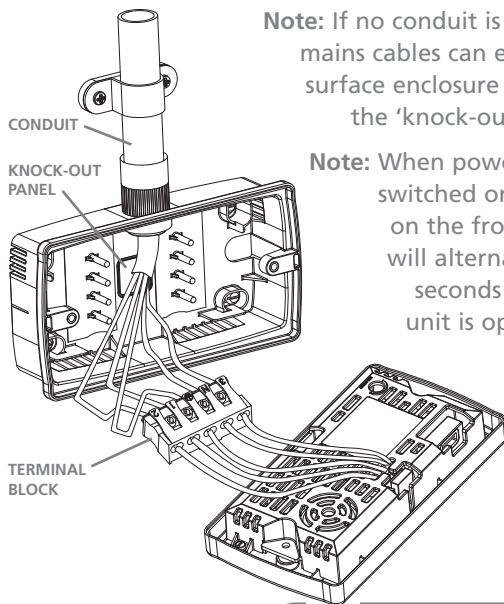

If fitting into a recessed metal wall enclosure use a metal enclosure of 35mm minimum depth.

Note: Ensure the metal box is earthed.

4

E With power connected; press lowest speed button on keypad (see diagram). The fan will temporarily run to full speed for approximately 10 seconds (this is to overcome static friction).

F Using a screwdriver; adjust the minimum speed control on the back of the fascia & capsule assembly (see diagram).

Note: Adjust fan speed so that fan is running at just above its stalling speed.

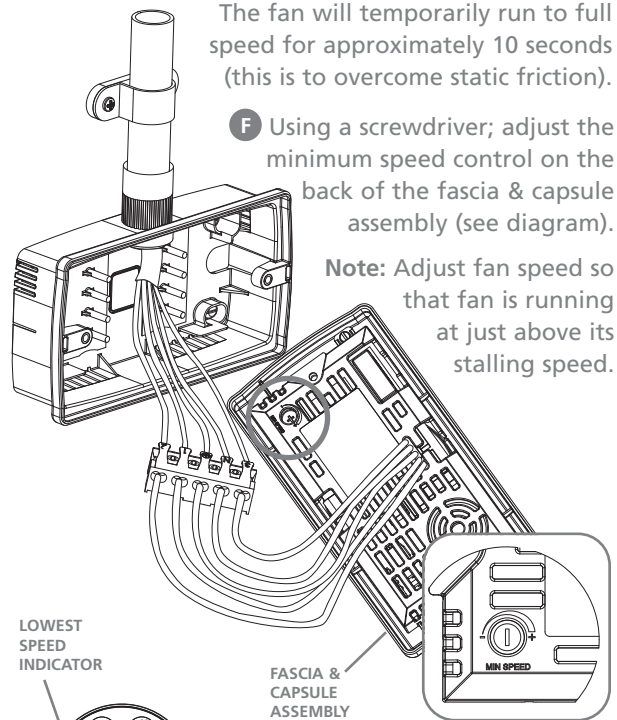

LOWEST SPEED INDICATOR

FASCIA & CAPSULE ASSEMBLY



CAUTION Electrical shock hazard may exist

5

G Push terminal block firmly into pegs (2 position options - *surface mount only*) until seated down firmly. Ensure that the cables are laid in the most suitable place to prevent pinching or straining of the connections.

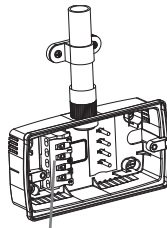

LH TERMINAL BLOCK POSITION

H Locate the fascia and capsule assembly onto the enclosure and secure using the 2 screws supplied.

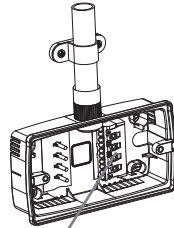

RH TERMINAL BLOCK POSITION

Note: The fascia and capsule assembly should be fitted in the orientation shown.

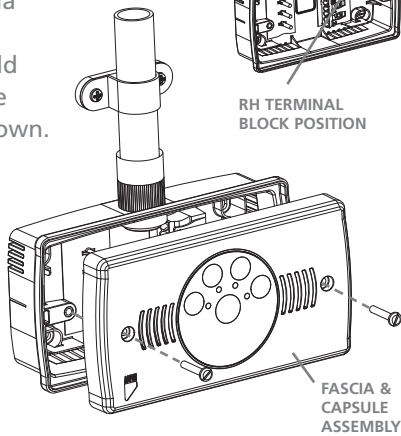

FASCIA & CAPSULE ASSEMBLY

6

I The fascia and capsule assembly should be fitted in the orientation shown.

Note: Use minimum 35mm depth box.

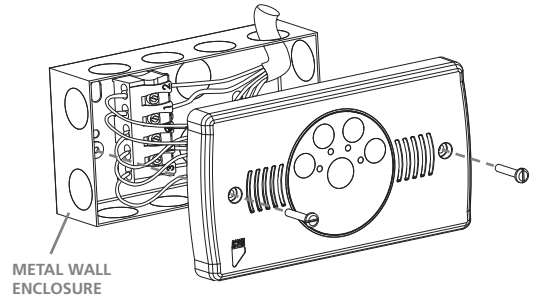

METAL WALL ENCLOSURE

Electrical specification

- Model VFSC/2 230V 2A 50Hz fused
Model VFSC/4 230V 4A 50Hz fused
- Normal equipment operating is 0 to 40°C ambient
At maximum current continuous operation at 30°C ambient
- IP33 rated

Controller operation overview

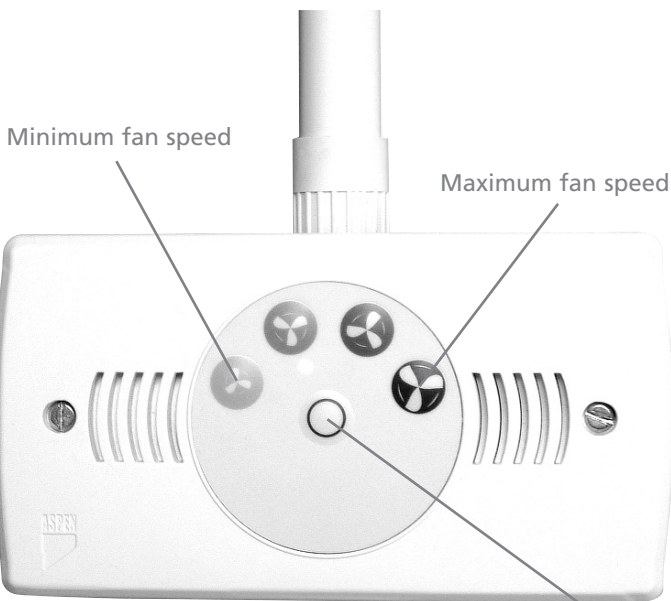

Minimum fan speed

Maximum fan speed

The unit is designed for continuous operation. On/off

IMPORTANT Before undertaking any work on this unit ensure electrical supply is disconnected. The installation must be carried out by suitably qualified personnel in accordance with all the appropriate statutory and governing regulations.

REPLACING THE FUSE The unit is fitted with a cartridge fuse. To replace the fuse, which is located in the back of fascia and capsule assembly: Remove fascia and capsule assembly, remove cartridge fuse and replace with identical specification fuse - 20mm antisurge ceramic fuse 2 amp or 4 amp depending on model.

COMPLIES WITH THE FOLLOWING STANDARD
(89/336/EEC amended by 92/31/EEC) (73/23/EEC amended by 93/68/EEC)
(89/392/EEC amended by 91/368/EEC) (93/44/EEC amended by 93/68/EEC)
(BSEN 60335-1: 2002 part 1) (BSEN 60335-2-80: 2003)

**Aspen Pumps Apex Way
Hailsham East Sussex
BN27 3WA UK
T: +44 (0) 1323 848 842
F: +44 (0) 1323 848 847
E: sales@aspenpumps.com**

