



Technical Specification | Beverage Pumps

Column Pumps

Part No: 1 Stage FP2863 / 2 Stage FP2864
3 Stage FP2865 / 4 Stage FP2866

ASPEN-5/09

Dimensions (mm):

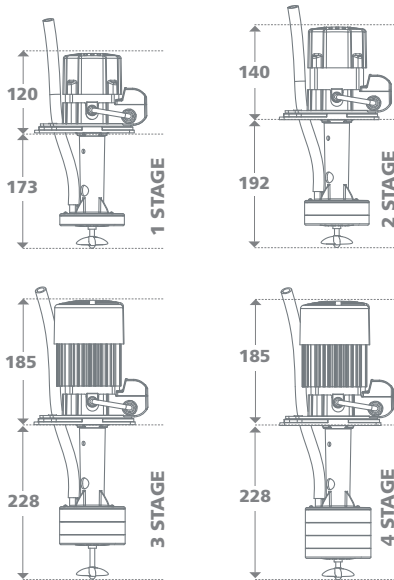

Electrical Connections:

Brown: Live
Blue: Neutral
Green/yellow: Earth
2 x Black: Safety switch

Other Features:

- Temp: -20°C to +90°C
- Shaft: 316 Stainless steel
- Sealed upper and lower bearings
- Motor IP54 rated (excluding Miniature column pump)
- All pumps supplied with agitator



The four Aspen Column pumps are designed primarily for beverage chillers, to continuously pump chilled water around a python system to provide the optimum cooling rate for soft drinks and cold beverages.

Mounting plate:

122mm x 149mm

Mini Column Pump:

Above fixing surface: 76mm
Below fixing surface: 116mm
Fixing plate: 136.5mm x 90mm
Weight: 140kg

QUICK TWIST RELEASE



Performance:

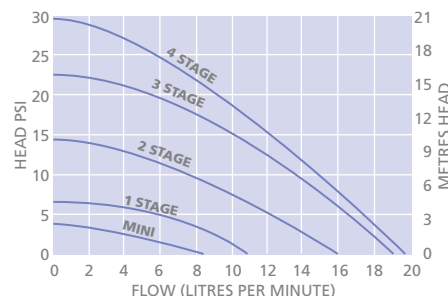

Power Supply:

Motor options:

- 230V-1Ph-50Hz thermally protected

- 110V-1Ph-60Hz

Other motors available on request

Once the mounting plate is fixed to the water tank, any of the four interchangeable pumps can be fitted by simply twisting the pump so it locks securely into the bayonet detail on the plate. The pumps are just as quick to release from the plate, without the need to remove the outlet tube. With minimal installation costs and low maintenance, these pumps are ideal for both direct installers and the replacement market.

Miniature Column Pump

For small chiller and recirculation duties, this pump offers high performance and quality at low cost. The pump is typically used in vending machines but can be adapted to suit many different markets.



Apex Way Hailsham
East Sussex BN27 3WA
T: +44 (0)1323 848842
F: +44 (0)1323 848846
sales@aspenspumps.com
www.aspenpumps.com